



# Company Profile

Jan 2019

# Table of Contents

Introduction

Our Business

*Engineering , Procurement, Construction, Commissioning  
Operations & Maintenance  
Track Record*

Our Team

*Organization Chart  
Management Team*

The Company

*General Information  
Quality Assurance  
HSE Commitment*

Licenses & Registrations

# Introduction

**Dyna Segmen Sdn Bhd (Dyna)** was incorporated in 2004 as an engineering services and equipment supplies company, with clients ranging from the Oil & Gas, Power, Water and Construction industries. Dyna, backed by the vast knowledge and experience of its management team, has grown to be a trustworthy company in providing solutions to clients. The company is ISO 9001 and ISO 18001 certified.

## Drawing the Experience

The team in Dyna combines more than 100 years of experience in the various industries, with members serving the National Oil Company of PETRONAS, oil majors like ExxonMobil, global service provider leaders like Honeywell and local public listed companies. Among the key experiences are:

### **Oil & Gas** and **Power** industries

Specialist in Fabrication, Hook-up and Commissioning, Operations & Maintenance for onshore & offshore facilities

Turnaround and shutdowns; clients include PETRONAS, Shell, ExxonMobil.

Engineering Solutions.

## Key Clients



### **Civil** industry

Soil investigation and rectification works

Construction of steel structures and process skids.

Specialized in Polyurea & Polyurethane foam coatings. Construction of chiller tanks.

Slope mitigation works

## Our Commitment

Engineering is more than just mechanical parts and automated processes. It is, to an extent, an art, which requires the human touch to weave awe-inspiring results.

Here at Dyna, we go the extra mile to personally ensure that our clients are happy with our products and services. Trust is built by delivering quality results in a timely manner. We value our businesses with our ever-growing list of clients, and are committed towards building long-term relationships.

Dyna is a young company, but Dynamic. It is an exciting stage of the company, with exponential growth over the past few years. Whether you are our client, principal, staff or even intern, we welcome you to join us in striving for excellence.

# Our Business Engineering

## Civil & Structural

Dyna collaborates with local university professors in the field of earthwork and soil subsidence mitigation solutions. Specializing in the O&G industry, our clients include refineries and petrochemical plants, which have faced subsidence problems over the years of operations. The company also has experience in civil buildings, having worked with C&S Engineering firms for several O&G projects.



## Mechanical & Piping

One of the challenges in onshore and offshore facilities is in deteriorating pipes and fittings. Dyna is involved in engineering solutions, having designed replacement piping systems and engineered online repair and inspection methods which have saved clients from downtime.

Dyna also works with M&E engineering firms for civil works within the O&G industry.

## Electrical & Instrumentation

MOVs and HVACs are some of the E&I systems which Dyna designs and engineers. Being the agents for specialized products such as valves, actuators, transmitters and gauges, Dyna works hand-in-hand with manufacturers to design E&I systems for clients.



## Offshore

Dyna is involved in several proposed projects for clients in the region. The project entails naval and structural engineering, ranging from FPSO conversion to drilling rigs to MOPUs and FPU's.

Dyna also designs process skids for floaters.

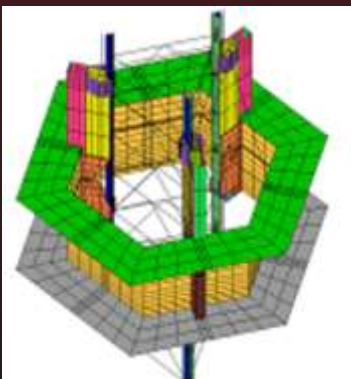

In collaboration with



# Our Business Procurement

Dyna has been procuring equipment, material, spares and consumables for O&G majors and Power Plants for the past 8 years. We procure and deliver thousands of items annually, ranging from structural to mechanical to E&I.

## Electrical & Instrument

### Scope of Procurement

- Temperature Transmitters & Gauges
- Pressure Transmitters & Gauges
- Vibration Transmitters
- Switch Controllers
- Electric and Hydraulic Actuators
- Flow Meters
- Well Head Control Panels
- Fire & Shutdown Systems/ Panels
- Signal & Power Cables
- HVAC

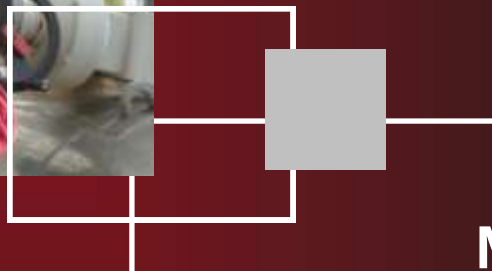

## Mechanical

### Scope of Procurement

*Valves:*  
*Gate, Ball, Choke, Check, Butterfly*  
*Pipes, Elbows, Tees*  
*Steel Plates & Bars*  
*Flanges, Fittings, Saddles*  
*Clamps, Supports, Nuts & Bolts*  
*Engine/ Generator Parts*



# Our Business

## Construction

Dyna is a G7 (CIDB/ Class A SPKK) company, licensed to undertake Civil, M&E and Building contracts of unlimited values.

Dyna is involved in **construction of steel structures**, e.g. jackets and topsides for O&G platforms. Among the clients are SHELL and ExxonMobil. The team members were also entrusted to supervise the construction, commissioning, operation and decommissioning of Malaysia's first ever FPSO.



The company also does the **construction of buildings**. The most recent project is in the construction and insulation on a chiller tank for a new mall in Klang Valley. Apart from new construction, Dyna also does extensive renovation works.

Dyna is involved in **soil investigation and rectification** works. Among our clients are refineries and petrochemical plants.



The team also specializes in **slope mitigation** works. Malaysia, being a tropical country, gets a lot of rain which causes erosion and landslides on hills and slopes. Dyna works with Propel to design mitigation systems.



Protective coating is another area where DYNA is active. Water proofing of commercial buildings and anti-corrosion works (Corrosion Under Insulation Management, etc) are amongst our specialization.



# Our Business

## Commissioning

The team in Dyna was responsible for the commissioning of the first FPSO in Malaysia, the Armada Perkasa. Dyna was also involved with the commissioning and decommissioning of the MOPU Rubicone (2011/2013). Apart from these offshore projects, there have been several onshore commissioning works including Tank Truck Loading facilities, and a new piping system at a Petrochemical Plant.

In collaboration, we are active in Hook-up and Commissioning works:

*PMT personnel AND Offshore Construction personnel for Carigali-HESS HUC Brownfield Retrofit Projects*  
(EPIC Mushtari Engineering)(2012-2014)

PMT personnel for PCSB SKO Pipeline Rejuvenation  
(Petra Resources)(2012-2013)

*PMT personnel for Carigali-HESS HUC Brownfield Retrofit Projects*  
(EPIC Mushtari Engineering)(2009-2010)

*Offshore Construction personnel for Carigali-HESS HUC Brownfield Retrofit Projects*  
(EPIC Mushtari Engineering)(2009-2010)

Supply of Electrical & Instrumentation Engineer  
(Oilfab)(2008-2009)

Supply of Project Engineer  
(Oilfab)(2008-2009)

Work pack Development works  
(Oilfab)(2009-2010)

Engineering, Procurement, Construction, Load-out and Seafastening for WHP Jackets and decks.

Pre Commissioning and Commissioning of Phase 1 works for Carigali PTTEPI Operating Company JDA B17 Field Development Project  
EPCC of Four Wellhead Platforms (MDA, MDB, MDC, & JKA)  
(Oilfab)(2007-2009)



In collaboration with



# Our Business Operations



The complete operations team, comprising of the OIM, Superintendent, Production and Maintenance Supervisors, operators and maintenance crew is done by Dyna Segmen Sdn Bhd. The daily production (crude and gas) is being run by Dyna's team. Apart from manning the control room, our staff are also responsible for site activities such as manual operations of valves, gauge readings, sampling, and other activities required for the safe operations of the offshore facilities.



One of the main challenges of offshore operations is the maintenance of the equipment on board. The major items are the compressors and generators, along with complicated process equipment such as the Glycol and Separator systems. Dyna runs a Computerized Maintenance Monitoring System (CMMS) on board, and ensures top-notch maintenance of the facilities. Apart from Rubicone, Dyna also services other facilities. The company has expertise in carrying out overhauls of main engines; every year, Dyna is called on board to service FPSO/ FSOs servicing offshore Malaysia/ Thailand.





# Our Business

## Surveillance Lens

### Drone Inspection

Drones are high-tech aircraft that are remotely controlled. These devices are not only cost-effective, but they are strongly effective in their surveillance abilities. Our Drones can be equipped with various pieces of equipment such as daytime video recorders, low visibility surveillance video, live feed cameras, radar sensors, digital cameras, radio equipment, infrared cameras, sound recorders, laser scanners, thermal imaging and GPS equipment.



Our inspection capabilities through remote Aerial operated Vehicle (RAOV) often include but are not limited to:

- Offshore platform flare
- Road pavement inspection
- Slope inspection
- High rise building inspection

### CCTV

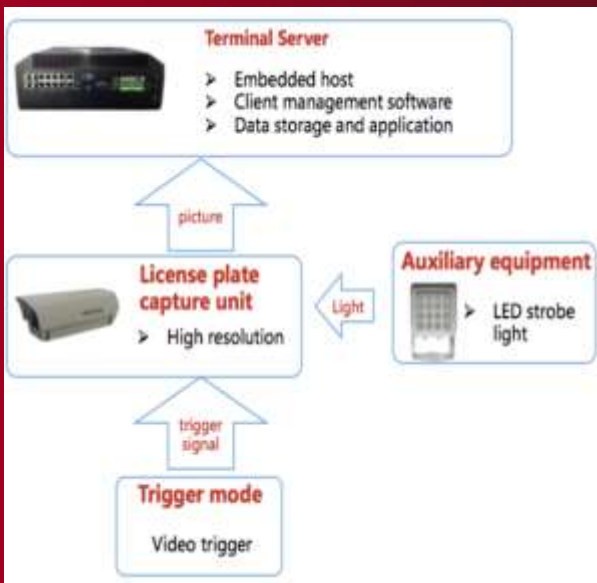

### Container Code Recognition

- Can ID: 20 ft, 40 ft & 48 ft boxes etc.
- Distinguish between single & double box function
- Automatic identification of container numbers
- System recognition rate  $\geq 95\%$

### Vehicle Plate Recognition

- Records 24 hours
- If speed is less than 30km/hr able to record ID info
- Info stored for more than 3 months
- Adapt to a variety of complex environments
- Info recording accuracy  $\geq 95\%$

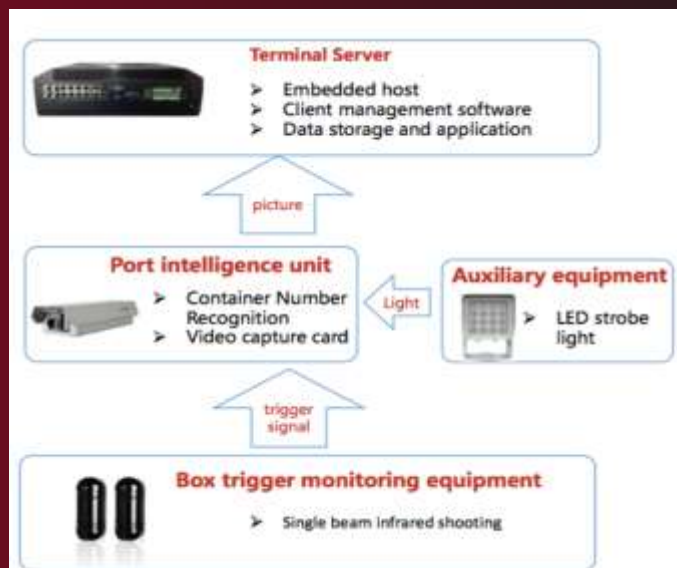

The basic functions include but are not limited to: Video Surveillance Management, Remote Control Management, Video playback, Review & System Diagnostics & Audio Management etc.

# Our Business

## Maintenance

Dyna carries out **Mechanical, Civil, Refractory Services, and E&I installations and maintenance** for new and old facilities.

### Mechanical

Online repair of corroded/eroded conduits, major overhaul of engines and generators, servicing valves and actuators, tank inspection, profiling, demucking, sludge/ waste management and cleaning, blasting & painting, Polyurea and Polyurethane applications.

We've also recently adopted smart coating removal technique (Heat Induction Coating Removal) which is significantly advantageous over traditional methods (blasting & etc.)

Besides, DYNA also offers a Total CUI (Corrosion Under Insulation) Management program and cutting-edge corrosion inspection technique (Advanced Phonon Testing).



### Civil & Building

Rectification of ground subsidence, water proofing, insulated chiller tanks. Building maintenance work.



### Refractory

DYNA also offers multi-disciplined services for refractory such as installation, turnaround, maintenance, upgrade, and etc.



### E&I

MOV maintenance, actuator replacement, signal and power cabling works, replacement of transmitters, gauges, flow meters, HVAC maintenance.

# Engineering Track Record

No	Project Details	Client	Date
1	Slope protection engineering & design using Polyurea on Geotextile. PLUS Highway, km260 North Bound.	PLUS/ OPUS	Nov-08
2	New FRP piping system— Engineering, design and installation.	PETRONAS VCM	Jan-11
3	Design and construction of control room (civil renovation)	PETRONAS PFK	Apr-13
4	Tank Truck Loading Rack (TTLR) Bitumen line. Engineering, calculations MOV.	PETRONAS Dagangan	Dec-13
5	Soil subsidence engineering calculations and system design using Polyurethane injection.	PETRONAS MTBE	Jan-14
6	Conceptual design—Angsi CEOR. Jack-up barge for water intake.	PETRONAS Carigali	Jun-14
7	Conceptual design, Multipurpose Jack-up unit with 200 men accomodation	PETRONAS Carigali	Sep-14
8	Conceptual design, feasibility study FPU on Ophir marginal field development	OPHIR (PETRONAS, Scomi, Octanex JV)	Jan-15
9	Pipeline repairs. Engineering calculations to rehabilitate to design and operating temperatures and pressures	Various: PETRONAS (upstream & downstream), SHELL, Talisman, Qatar Petroleum	2009-present

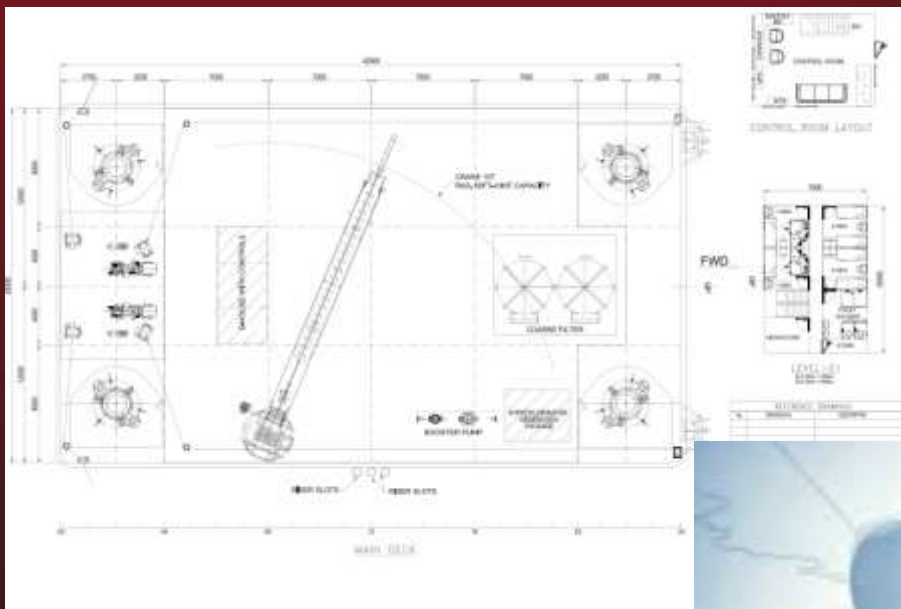

# Procurement Track Record—E&I

No	Project Details	Client	Date
1	Elcometer Digital Surface Profile	PETRONAS Ammonia	Sep-08
2	Auma Protection Cover	Exxonmobil	Nov-08
3	Auma Motor	CUF Gebeng	Mar-09
4	Vibration Transmitter	PETRONAS Gas Berhad	Jun-09
5	Stromag Limit Switch	ARCHCO	Sep-09
6	2Amp Charger	ARCHCO	Sep-09
7	Sensor and Transmitter	PETRONAS Gas Berhad	Sep-09
8	Vibration Transmitter & Thermowell	PETRONAS Gas Berhad	Sep-09
9	Auma Actuator	PETRONAS VCM	Oct-09
10	Temp Gauge	PETRONAS VCM	Oct-09
11	Temperature Controllers	SARAWAK SHELL	Oct-09
12	Rosemount and Yokogawa Transmitters	SARAWAK SHELL	Jan-10
13	Rotary Handle	ARCHCO	Feb-10
14	Pipeline Labels	Talisman	Feb-10
15	8 Actuator Replacement	Exxonmobil	Apr-10
16	Safety barriers for transmitter	SARAWAK SHELL	Jun-10
17	Rosemount Temperature Transmitter	PETRONAS Carigali	Aug-10
18	Vaisala Temperature Transmitter	SARAWAK SHELL	Sep-10
19	KELE temperature transmitter	SARAWAK SHELL	Nov-10
20	Electric Components	Alam Dingin	Jan-11
21	Rosemount Diff Transmitter E8kF13k	Simoda Engineering	Dec-11
22	Wika Gauge	Technip Geoproduction	Feb-12
23	Rosemount Transmitter	PETRONAS Carigali	Mar-12
24	Rosemount Transmitter	PETRONAS Carigali	Sep-12
25	Temperature Transmitter	Carimin Engineering	May-13
26	Rosemount Temperature Transmitter	PETRONAS Carigali	May-13
27	Yokogawa temperature transmitter	Carimin Engineering	Jul-13
28	of Temperature Transmitter	Petrofac	Jul-13
29	switch temperature, themocouple, gauge	PETRONAS Gas Berhad	Aug-13
30	Solenoid Switch	SARAWAK SHELL	Nov-13
31	Hygood Actuators	PETRONAS Gas Berhad	Dec-13
32	Actuator (Valvcon)	PETRONAS Gas Berhad	Jan-14
33	Light ballast	Malakoff Power	Nov-14
34	Kidde Electric Solenoid	SARAWAK SHELL	Mar-15

# Procurement Track Record—Mechanical

No	Project Details	Client	Date
1	Workshop Tools	Talisman	May-09
2	Saddle piping	SABAH SHELL	Jul-09
3	Valco Valve	PETRONAS Gas Berhad	Aug-09
4	Handle & Monoflange	PETRONAS VCM	Aug-09
5	Pipes, flanges, reducer	MTBE Malaysia	Oct-09
6	U-bolt	SARAWAK SHELL	Nov-09
7	GRE Pipes	SARAWAK SHELL	Nov-09
8	Pipe plugs and Bushings	SARAWAK SHELL	Dec-09
9	O-Ring	PETRONAS Gas Berhad	Dec-09
10	CPVC Pipe	Talisman	Jan-10
11	Surface Replica Mould system	SARAWAK SHELL	Jan-10
12	O-ring kits	Talisman	Feb-10
13	Anfomatic Anode	ARCHCO	Mar-10
14	Saddle Pipe	SABAH SHELL	Sep-10
15	Steel Item for Pipe Support	FSPO VENTURES	Sep-10
16	PIPE REDUCER & PIPE PLUGS	SABAH SHELL	Oct-10
17	Rod/Bar	FSPO VENTURES	Oct-10
18	Hydrowrap-argosy	SARAWAK SHELL	Nov-10
19	Pipe Support Materials	Dayang Enterprise	Nov-10
20	ABS Saddle	Dayang Enterprise	Dec-10
21	Grayloc Clamp	PETRONAS Carigali	Jan-11
22	epoxy pipe fittings	SABAH SHELL	Jan-11
23	FRP Pipe Replacement	PETRONAS VCM	Jan-11
24	RAPP-IT BANDAGES	Talisman	Feb-11
25	TRIAC Actuator	Penaga Dresser	Feb-11
26	Pipe Reducer	SARAWAK SHELL	Jun-11
27	U Bolt and Pipe Saddle	Kencana Petroleum	Jun-11
28	Bettis Actuator Repair Kit	PETRONAS Gas Berhad	Jun-11
29	Grayloc	PETRONAS Carigali	Jul-11
30	Triac Actuator	Penaga Dresser	Jul-11
31	Steel Material	Petra Energy Berhad	Jul-11
32	Instrument Support	Petra Energy Berhad	Aug-11
33	flange and plug	MLNG	Nov-11
34	flange and plug	MLNG	Nov-11

# Procurement Track Record—Mechanical

No	Project Details	Client	Date
35	Flange and Nipple	MLNG	Nov-11
36	TUBES	MLNG	Nov-11
37	Grayloc product-Blind Hub	PETRONAS Carigali	Nov-11
38	Steel Material	Petra Energy Berhad	Nov-11
39	carbon pipe	MLNG	Dec-11
40	carbon pipe	MLNG	Dec-11
41	Pipe Support	Petra Energy Berhad	Dec-11
42	Ashcroft gauge	Technip Geoproduction	Jan-12
43	tee 1/2" and Flange 1/2' to MLNG	MLNG	Mar-12
44	Glass Reflex	PETRONAS Carigali	Mar-12
45	variable spring support	MLNG	Apr-12
46	Pipe fittings - 32 items (M001-12031) PO - 87	MLNG	May-12
47	variable spring support	MLNG	Jun-12
48	nipple thread	PETRONAS Carigali	Jul-12
49	Parker Monoflange	PETRONAS VCM	Jul-12
50	pipe + fittings (4 items)	MLNG	Jul-12
51	1in PVC pipe	SABAH SHELL	Jul-12
52	Grayloc Seal Ring	Petrofac	Jul-12
53	Pipe Saddle & Nu-Bolt	SARAWAK SHELL	Jul-12
54	Pipe Support and Accessories	SHAPADU	Aug-12
55	Concentric Pipe Reducer	SABAH SHELL	Aug-12
56	Flange to PEMSB	PEMSB	Sep-12
57	Pipe fittings - 32 items (M001-12031) PO - 85	MLNG	Sep-12
58	Flange To PEMSB	PETRONAS Polyethelene	Oct-12
59	Board,Fibre,Unifrax	SABAH SHELL	Oct-12
60	tees & adhesive	SARAWAK SHELL	Nov-12
61	line pipe - Samarang Phase 2	Carimin Engineering	Dec-12
62	Pipe Support	Carimin Engineering	Dec-12
63	Bondstrand Pipe Fittings.	SARAWAK SHELL	Jan-13
64	I-Rod and Nu-Bolts to Shapadu	SHAPADU	Jan-13
65	studbolt and nuts	Carimin Engineering	Feb-13
66	Flanges	SARAWAK SHELL	Feb-13
67	Seal Ring (Grayloc Products)	PETRONAS Carigali	Feb-13
68	gasket - Samarang Phase 2	Carimin Engineering	Feb-13

# Procurement Track Record—Mechanical

No	Project Details	Client	Date
69	UPVC Pipe Fittings	Petrofac	Feb-13
70	ANODE FOR SEA WATER LIFT PUMP (SWLP)	Petrofac	Feb-13
71	Norgren Air Filter	PETRONAS Carigali	Mar-13
72	Pipe Clamp (CEAG)	PETRONAS Carigali	Apr-13
73	Whru Actuator	Talisman	May-13
74	Zinc Corrosion Inhibitor Rod	Petrofac	May-13
75	Pipe Support Material(BEKOK A)	SHAPADU	May-13
76	Nu-Bolts (3 years contract) #1 -4511692092	SARAWAK SHELL	Jun-13
77	Pipe Support	Carimin Engineering	Jun-13
78	line pipes elbow	MLNG	Jun-13
79	Nu-Bolts (3 years contract) #3 - 4511704042	SARAWAK SHELL	Jun-13
80	Nu-Bolts (3 years contract) #2 -4511692093	SARAWAK SHELL	Jun-13
81	Gasket	Carimin Engineering	Jul-13
82	Nu-Bolts (3 years contract) #6-4511719622	SARAWAK SHELL	Jul-13
83	Nu-Bolts (3 years contract) #5-4511706958	SARAWAK SHELL	Jul-13
84	pipe support-7 (c-chanel)	Carimin Engineering	Jul-13
85	fittings (BEKOK A)	SHAPADU	Jul-13
86	BINDER Spring Hanger	SARAWAK SHELL	Jul-13
87	fittings	Carimin Engineering	Jul-13
88	Bolt Coupling	PETRONAS Carigali	Aug-13
89	Fittings	Carimin Engineering	Aug-13
90	Studbolt & Nut	Carimin Engineering	Aug-13
91	BAKER CAC Hydraulic Actuator	PETRONAS Carigali	Aug-13
92	Deliver Hbeam, C channel, angle iron, flat bar	SHAPADU	Aug-13
93	Nu-Bolts (3 years contract) #9 -4511746157	SARAWAK SHELL	Aug-13
94	Nu-Bolts (3 years contract) #8 -4511746152	SARAWAK SHELL	Aug-13
95	Nu-Bolts (3 years contract) #7 -451176061	SARAWAK SHELL	Aug-13
96	transmitter-Rosemount	PETRONAS Carigali	Sep-13
97	WOODWARD ACTUATOR KIT	PETRONAS Carigali	Sep-13
98	Kerneos Cement	SARAWAK SHELL	Oct-13
99	Nu-Bolts (3 years contract) #10 - 14	SARAWAK SHELL	Oct-13
100	Spring Support	MLNG	Oct-13
101	Nu-Bolts(3 years contract) #15-17	SARAWAK SHELL	Dec-13
102	Nuts and Bolts	SARAWAK SHELL	Feb-14

# Procurement Track Record—Mechanical

No	Project Details	Client	Date
103	Polymer Desiccant and Protection Coating	SARAWAK SHELL	Feb-14
104	AUTOMAX#S200S10, SUPERNOVA, ACTUATOR	Exxonmobil	Mar-14
105	WrapSeal 4' X 12' Kit 20 Rolls	PETRONAS Carigali	Mar-14
106	Nu-Bolts(3 years contract) #18-19	SARAWAK SHELL	Mar-14
107	Nu-Bolts(3 years contract) #26-33	SARAWAK SHELL	Apr-14
108	Nu-Bolts(3 years contract) #20-25	SARAWAK SHELL	May-14
109	Pipe Support (Nu-Bolt)	Petra Energy Berhad	May-14
110	Motor Operated Valve/Actuator	PETRONAS Ethylene	Jun-14
111	Defective Mounting Kit	Petrofac	Jun-14
112	I-rod	SARAWAK SHELL	Jul-14
113	IROD	PETRONAS Carigali	Jul-14
114	AUMA Spare Part	ANZ Engineering	Jul-14
115	Nu-Bolts (3 Years Contract)#61-67	SARAWAK SHELL	Aug-14
116	Nu-Bolts (3 Years Contract)#34-60	SARAWAK SHELL	Aug-14
117	Nu-Bolts (3 Years Contract)#68-70	SARAWAK SHELL	Sep-14
118	Nu-bolt 3years term contract (from September)	SARAWAK SHELL	Sep-14
119	Structure Material	Carimin Engineering	Oct-14
120	OLAER Bladder Accumulator	Malakoff Power	Oct-14
121	Nu-Bolts (3 Years Contract) #71-78	SARAWAK SHELL	Oct-14
122	Small Tools & Mach Tools, Gen	OPTIMAL Chemicals	Nov-14
123	Vacuum Shape for Primary Steam Reformer	PETRONAS Methanol Labuan	Jan-15
124	blasting and painting at SAMUR project	HGS	Feb-15
125	Nu-Bolts (3 years contract) #81-87	SARAWAK SHELL	Feb-15
126	Nu-Bolts (3 Years Contract) #100-114	SARAWAK SHELL	Feb-15
127	Saddle Pipe(3 Years Contract)	SARAWAK SHELL	Feb-15
128	RTD and Thermocouple (Petronas)	PETRONAS Gas Berhad	Mar-15
129	14" PERMANENT FLANGE COATING	Sapura Kencana	Mar-15
130	Valves	MTBE Malaysia	Mar-15
131	Nu-Bolts (3 Years Contract) #115-117	SARAWAK SHELL	Mar-15
132	Ansul Electric Actuator	PETRONAS Carigali	Mar-15
133	Nu-Bolts (3 years contract) #88-99	SARAWAK SHELL	Mar-15
134	Channel, Ball and Gate VALVE	PETRONAS Methanol	Mar-15
135	Nu-Bolts (3 years contract) #4 - 4511716846	SARAWAK SHELL	Mar-15



# Construction Track Record

## **Soil works—**

PETRONAS Gebeng (2013)

## **Slope Works—**

PLUS Highway (2007)

## **Construction (Civil) —**

Chiller Tank (Mall in Klang Valley) (2013)

Chiller Tank (IOI Mall, Purajaya) (2014)

Coal conveyor towers (Tg Bin) (2014-present)

## **Steel Construction —**

E8DRA (Shell) Topside and Jacket (2005)

E11 (Shell) Jacket (2005)

Guntong E (ExxonMobil) Jacket (2005)

Gemusut (Shell) Column (2007)

CPOC (PETRONAS) Skids (2007)

## **Renovation / Rectification Works—**

PETRONAS Control Room Kedah (2012)

UN Building Bangkok (2012)

## **Piping Works —**

E8DRA (Shell) (2005)

## **Blasting & Painting projects —**

Sumandak (PETRONAS) (2006)

## **Polyurea Coating of—**

Bekok & Pulau Pressure Vessel (2007)

Integrity Malaysia Building (2008)

PLUS Highway Slope (2008)

Segari Power Cooling Tower (2009)

M3nergy Pressure Vessel (2010)

Kapar Power Plant (2011)

Tg Bin Power (2011-2012)

UN Building, Bangkok (2012)

## **Corrosion Protection —**

Tg Bin Power Plant(2011-present)

PETRONAS Gas Berhad (2012)

## **Hydrojetting—**

BASF (30,000 psi) (2013)

Titan (30,000 psi) (2013)

Polyethelene (2015)



# Operations Track Record

## The Contract and Performance:

Client: PETRONAS Carigali  
 Period: July 2011 – September 2013 (2 years +)  
 Total Man-hours: 821,108  
 Total Loss Time (LTI): 0  
 Total Up-time: 93% (inclusive of planned shutdown/ maintenance)



### The MOPU Rubicone:

The main equipment on board are the Production Separator, Slug Catcher, Glycol Units, Suction Scrubber, Booster Compressor and Export Compressor. Power is generated by 2 CAT (hull) and 2 MTU (topside) engines with a combined capacity of >3MW.

Gas export of about 100mmscf/day.

The simplified process as below:

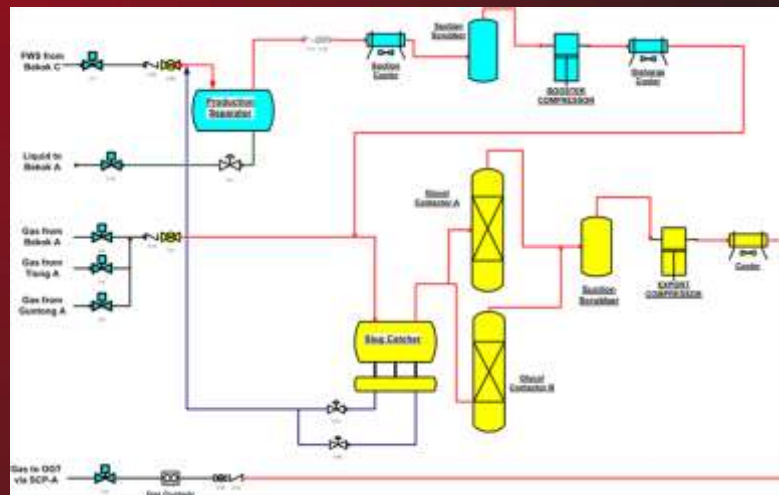

# Surveillance Video Track Record— Drone

No	Project Details	Client	Date
1	ROAV inspection of Elevated Flare (MEF) & Acid Gas Flare (AGF) online	PETRONAS Chemicals Ethylene Sdn Bhd (PCESB)	Dec-17
2	DJI Drone Rental	PETRONAS GAS Berhad (PGB)	June-17

# Maintenance Track Record—Civil, Building

No	Project Details	Client	Date
1	Central Room Renovation	PFKSB	Apr-13
2	Maintenance Services (Civil & Structural)	Uni Tek PETRONAS	Mar-14– present
3	Metallic Hardener Topping	ThyssenKrupp	Oct-14

# Maintenance Track Record—Blast & Paint

No	Project Details	Client	Date
1	manpower & consumables-MPI-KLIA	Ingress	Sep-10
2	LEKAS Stainless Steel Paint	Ranhill	Mar-12
3	Blasting and Painting maintenance	Teknik Janakuasa	Apr-12
4	LEKAS Stainless Steel Paint 2	Ranhill	May-12
5	LEKAS SS Paint 3	Ranhill	Aug-12
6	Blasting painting & insulation of Serdang	PETRONAS Gas Berhad	Nov-12
7	B&P & Insulation Replacement	Vision One	Nov-12
8	PE-1-R-200 HPWJ	PETRONAS Polyethelene	Mar-13
9	MCW Pipe Internal Coating	Teknik Janakuasa	May-13
10	R-200 Wall Polishing Work	PETRONAS Polyethelene	Oct-13
11	MCW Internal Pipe Lining U30	Malakoff Power	Nov-13
12	HPWJ & Polishing Reactor R200	HSE Resources	Jan-14
13	Pasir Gudang Metering Station Painting	PETRONAS Gas Berhad	Nov-14
14	Painting of Valves and Spools	Misi Setia Oil & Gas	Dec-14
15	Coating Repair Works	PETRONAS Gas Berhad	Feb-15
16	BLASTING & PAINTING	IDM GLOBAL RESOURCES	Apr-15

# Maintenance Track Record—Polyurea

No	Project Details	Client	Date
1	Institut Integriti Malaysia roof waterproofing	Fosroc	Jun-05
2	Plus Highway Slope Maintenance	Majutani Keda	Mar-09
3	Internal Lining 3 vessels	MSET	Aug-10
4	Sea water pipe coating	TNB Kapar	Aug-11
5	Boiler Room Coating & C4B Conveyor	TNB Kapar	Nov-11
6	United Nations Roof Polyurea Coating	Smart & Bright Co. Ltd	May-12
7	KL Sentral QA/QC	Anmas Corp	Oct-12
8	IOI Mall Tank Coating	Anmas Corp	Jan-13

# Maintenance Track Record—E&I

No	Project Details	Client	Date
1	Guntong & Lawit Installation	AUMA	Sep-08
2	Sarawak Shell Installation (Phase 1)	AUMA	Mar-09
3	MOV Tabu A	AUMA	May-10
4	Schischeck Actuator	Talisman	Mar-10
5	Schischeck Actuator	Perolehan Global	Jul-10
6	Schischeck Actuator	SARAWAK SHELL	Jul-10
7	Schischeck Actuator	PETRONAS Carigali	Sep-10
8	Schischeck Actuator	Newfield	Sep-10
9	Schischeck Actuator	MCT Engineering	Sep-10
10	Schischeck Actuator	Talisman	Oct-10
11	Schischeck Actuator	Simoda Engineering	Nov-10
12	Schischeck Actuator	Ophir Holding	Dec-10
13	Schischeck Actuator	Proeve Resources	Feb-11
14	Schischeck Actuator	Simoda Engineering	Apr-11
15	Schischeck Actuator	Alam Dingin	Jul-11
16	Schischeck Actuator	Simoda Engineering	Sep-11
17	Schischeck Actuator	Alam Dingin	Oct-11
18	Schischeck Actuator	PFKSB	Oct-11
19	Schischeck Actuator	PETRONAS Penapisan (M)	Oct-11
20	Schischeck Actuator	Technip Geoproduction	Dec-11
21	Schischeck Actuator	PETRONAS Penapisan (M)	Jan-12
22	Schischeck Actuator	Alam Dingin	Feb-12
23	Schischeck Actuator	SARAWAK SHELL	May-12
24	Schischeck Actuator	PETRONAS Carigali	Apr-13
25	Schischeck Actuator	SARAWAK SHELL	May-13
26	SCHISHEK Humidity Transmitter	Alam Dingin	May-13
27	Schischeck Actuator	Newfield	Jun-13
28	Schischeck Actuator	PETRONAS Carigali	Aug-13
29	Schischeck Actuator	SARAWAK SHELL	Oct-13
30	Schischeck Actuator	Exxonmobil	May-14
31	Schischeck Actuator	SARAWAK SHELL	Sep-14
32	Schischeck Actuator	PETRONAS Carigali	Nov-14
33	Schischeck Actuator	SABAH SHELL	Nov-14
34	Schischeck Actuator	SARAWAK SHELL	Mar-15
35	Schischeck Actuator	PETRONAS Carigali	Apr-15

# Maintenance Track Record—Mechanical

No	Project Details	Client	Date
1	Cakerawala Diesel Engine Overhaul	M3energy Berhad	Sep-08
2	Pipe Support Repair	Teknik Janakuasa	Nov-08
3	Dye Penetration test	Ingress	Aug-09
4	Actuator Servicing	CUF Gebeng	Dec-09
5	NDT(PMI and DPI)	Ingress	Apr-12
6	Robotic In Site Tank Inspection	PETRONAS Methanol	Feb-13
7	Crude Tank Profiling T-7101 & T-71204	PETRONAS Penapisan (M)	Mar-13
8	FSO Generator Engine No. 3 & 4 Overhaul	M3energy Berhad	Jun-13
9	Actuator at TNB,Paka and CUF,Kerteh	PETRONAS Gas Berhad	Aug-13
10	EPCC 3 (TSO) valves	PETRONAS Dagangan	Dec-13
11	Choke Valve Hydrotesting	Flotrim	Dec-13
12	Cakerawala Diesel Engine Overhaul	M3energy Berhad	Dec-13
13	Vessel Fabrication	PETRONAS Polyethelene	Jan-14
14	Servicing Plasma Cutting Machine	MTBE Malaysia	Aug-14
15	Diesel Tank Sludge Cleaning at PTFI Papua	International Tank Services	Sep-14
16	Valve chamber repair	PETRONAS Dagangan	Jan-15
17	HPWJ & Polishing on Reactor	PETRONAS Polyethelene	Feb-15
18	PVRV Calibrations and repair for welding	PETRONAS Dagangan	Mar-15
19	Fireproofing Case for Actuator	PETRONAS Penapisan (M)	Apr-15



# Maintenance Track Record—Piping

No	Project Details	Client	Date
1	Joint Weld Repair - Diamond Wrap	PETRONAS VCM	Apr-10
2	Diamond Wrap (9 Joints)	PETRONAS VCM	Nov-10
3	DW Wrap 2" pipe	PETRONAS VCM	Mar-11
4	Pipe Wrapping	PETRONAS Ammonia	Mar-11
5	Diamond Wrap - 20" T-joint, 20"	PETRONAS VCM	Apr-11
6	DW 14" Clamped Straight Pipe	PETRONAS VCM	Sep-11
7	Dw 14" Elbow and 16" Straight Pipe	ESP	Oct-11
8	DW 28 in Clamp Pipe	PETRONAS VCM	Jan-12
9	DW 24in elbow	PETRONAS Ammonia	Feb-12
10	DW 2" 3 elbows & 1 tee joint	PETRONAS Ammonia	Mar-12
11	DW 2" Ball Valve	PETRONAS VCM	Mar-12
12	DW 28inch extend wrap	PETRONAS VCM	Apr-12
13	VCM DW 0.5in PT Pipe Thinning	PETRONAS VCM	May-12
14	VCM DW 28" extend wrap and box 3	PETRONAS VCM	Jul-12
15	DW unit 12, 3 location+ weld joints	PETRONAS VCM	Aug-12
16	DW Qatar 4in Clamped Elbow	Qatar Fuel Additives	Oct-12
17	DW Rejected Pipe Welds	Gryphon Energy Corp	Dec-12
18	DW 3in Straight Weld gas line	PETRONAS VCM	Dec-12
19	DW 24in 90 Deg Elbow and 24in 90 Deg	PETRONAS Ammonia	Dec-12
20	DW Term Contract Petronas Chemicals	T & S Timur Sdn Bhd	Jun-13
21	DW PCSB 3/4in + 16in Flange Weldolet	PETRONAS Carigali	Jun-13
22	DW 24in Elbow	PETRONAS Ammonia	Jul-13
23	PFCE DW 2in Pipe Resak Offshore Platform	PETRONAS Carigali	Aug-13
24	DW PPTSB 3 X 1in Straight Pipe	PETRONAS Penapisan (T)	Sep-13
25	DW Multi Line Wrappng Proposal	OPTIMAL Chemicals	Jun-14
26	DW Bunga Raya Pipeline Wrapping	Talisman	Sep-14
27	DW Petronas Optimal 3 Inch Pipe	T & S Timur Sdn Bhd	Sep-14
28	Emergency Wrap at South Angsi Alpha	Talisman	Oct-14
29	1" Ammonia Line DW Wrapping	PFKSB	Oct-14
30	3 X 1in DW Flange Wrap + 1in Flange Wrap	Kertih Terminals	Nov-14
31	DW Optimal 5 lines	T & S Timur Sdn Bhd	Nov-14
32	Pipe Wrapping	PETRONAS Ammonia	Jan-15
33	DW 4 Line Wrap	OPTIMAL Chemicals	Jan-15
34	Engineered Wrap on Bunga Raya-E Platform	Talisman	Jan-15
35	Offhsore 18 5/8 " Wellhead Casing DW	SEADRILL	Feb-15
36	Pipe and Support Corrosion Control	Boustead Petroleum	Feb-15

# Our Team



## Organization Structure



## Key Management Team

**Faiz H. Hussin (Co-founder & Director)** – A mechanical engineer graduate of North-eastern University Boston, USA, Faiz served PETRONAS (1997-2001), first as a shift supervisor at a petrochemical plant then as an oil trader. He headed Business Development at Bumi Armada Berhad before founding an O&G engineering company which was subsequently sold to a public listed company. Faiz brings a wealth of technical and entrepreneurial experience into Dyna Segmen and sets an energetic pace towards the growth and success of the company.

**Zaman Ahmad (Director)** is MD of Endeavor Malaysia, a non-profit organization that creates High Impact Entrepreneurs. Previously he was CEO of CaterhamJet Malaysia project. He was with AirAsia between 2010-2013 where he held various positions including Regional Head of Customer Experience Group (across 5 countries). Before AirAsia he served with PETRONAS for 13 years; as Electronic Systems Engineer: 1999 – 2000 for PETRONAS OPEL Touring Car and 2000 – 2005 for Team Sauber PETRONAS F1. He was promoted to Senior Manager of the Frontier Technology Unit, Research & Technology Division focusing on Renewable Energy and Upstream Technology and subsequently to Head of Technical Services at PETRONAS Ammonia. Kamarulzaman graduated with a Bachelor of Engineering (B.Eng) (Honours) degree in Electrical and Electronics from Imperial College, London. Apart from English and Bahasa Malaysia, he also speaks conversational level German.

**Hairani bin Hassan (Co-founder)** – Former MD of Ingress Fabricators, and GM at Bumi Armada Berhad. Hairani studied Mechanical Engineering at the Mara Institute of Technology and has a Masters in Business Administration. He has over 35 years of experience in the Oil & Gas Industry. Hairani climbed the ExxonMobil corporate ladder having started as a production specialist and eventually becoming a key superintendent, responsible for the overall stewardship, monitoring and coordination of operations for the Malaysian operations. He was the key personnel in implementing Malaysia's 1st FPSO while successfully completing the contract with Talisman. Hairani is a qualified facilitator and instructor in the oil and gas industry and has been involved in various committees particularly in safety and personnel development.

**M Sharif Mohd** – holds a BSc in Mechanical Engineering (1989- Cum Laude) from the University of the Pacific, California. He spent 6 years in ExxonMobil's Offshore Division. Joined Bumi Armada. in 1996 to supervise design engineering, procurement, fabrication, installation, commissioning, start-up and surveillance process facilities of an FPSO, the first in Malaysia, the MT Armada Perkasa.

**Nasrul Annuar** – A Missouri, USA mechanical engineer graduate, Nasrul is a hands-on Project Manager with vast experience in offshore & onshore facilities. He has managed projects on PETRONAS, ExxonMobil and Shell platforms, as well as a multitude of onshore facilities. He is qualified SSPC Level 2 Inspector.

# The Company

## General Info

### **Date of Incorporation**

7 September 2004

### **Authorized Capital**

RM 1,000,000

### **Paid-up Capital**

RM 1,000,000

### **Registered Address**

No.9 Tingkat Atas, Jalan Duku 2,  
Taman Sri Medan,  
42500 Telok Panglima Garang,  
Selangor, Malaysia.

### **Business Address**

Lot C12A- 4<sup>th</sup> Floor,  
Jalan Ampang Utama 1/1  
68000 Ampang,  
Selangor, Malaysia.

### **Telephone**

+60 3 4256-4254

### **Fax**

+60 3 4256-5254

**Operations** in Kerteh, Miri, Bintulu,  
K.Kinabalu, (Incheon/ Geoje, Korea)

### **Directors**

Faiz H. Hussin  
Kamarulzaman Ahmad

### **Company Secretary**

Haniza Ab Hamid

### **Auditors**

MH & Associates

### **Bankers**

CIMB Bank Berhad,  
Lot G35, Ground Level Suria KLCC,  
50088 Kuala Lumpur, Malaysia.

Maybank Berhad,  
2 Jalan Memanda 7, Ampang Point,  
68000 Ampang, Selangor, Malaysia.

Bank Islam Berhad,  
Jalan Raja Abdullah,  
50250 Kuala Lumpur, Malaysia.

SME Bank Berhad,  
Jalan Sultan Ismail,  
50250 Kuala Lumpur, Malaysia.





# The Company

-Quality Assurance



## CERTIFICATE OF REGISTRATION

The Quality Management Systems of

**DYNA SEGMENT SDN. BHD.**

C12A-4, 4<sup>th</sup> Floor, Jalan Ampang Utama 1/1, 68000 Ampang, Selangor, Malaysia

has been audited and found to conform to

**ISO 9001:2015**

for the following activities

**Provision of Mechanical and Civil Engineering  
Contracting Works for Oil and Gas Industry**

Date of Issue: 07 December 2016

Date of Expiry: 23 November 2019

Initial Certification: 25 November 2013

**Certificate No. 691946**

The validity of this certificate can be verified from the following website

[www.gicg.co.uk](http://www.gicg.co.uk)

A handwritten signature in black ink, appearing to be 'GIC'.

**Guardian Independent Certification Ltd**

*Registered in England*

*Sovereign House 212-224 Shaftesbury Avenue London England WC2H 8HG*

*Accredited by Member of the IAF MLA*



157788

045

# The Company

-HSE Commitment



## CERTIFICATE OF REGISTRATION

The Occupational Health and Safety Management Systems of

**DYNA SEGMENT SDN. BHD.**

C12A-4, 4<sup>th</sup> Floor, Jalan Ampang Utama 1/1, 68000 Ampang, Selangor, Malaysia

has been audited and found to conform to

**OHSAS 18001:2007**

for the following activities

**Provision of Mechanical and Civil Engineering  
Contracting Works for Oil and Gas Industry**

Date of Issue: 08 December 2016

Date of Expiry: 07 December 2019

Initial Certification: 09 December 2013

Certificate No. 691049

The validity of this certificate can be verified from the following website:

[www.gicg.co.uk](http://www.gicg.co.uk)

A handwritten signature in black ink, appearing to be 'D. M. M.', positioned above a horizontal line.

**Guardian Independent Certification Ltd**

*Registered in England*

Sovereign House 212-224 Shaftesbury Avenue London England WC2H 8HQ

JAS-ANZ registration no. C00906903L www.jas-anz.org/guide



125697

# Licenses & Registrations

PETRONAS

CIDB G7

SKPP

Ministry of Finance

Bumiputera Registration

TNB

Malakoff/Teknik Janakuasa

Syabas

Hyundai Engineering & Construction

Samsung Engineering

*... Delivering Results*



**Tel: +60 3-4256-4254**  
**Fax: +60 3-4256-5254**

**Contact: Faiz H. Hussin**  
*Director*  
**+60 19 279-8574**  
[fhussin@dyna.com.my](mailto:fhussin@dyna.com.my)

**Nur Farahin**  
*Corporate Affairs*  
**+60 13 666-4174**  
[farahin@dyna.com.my](mailto:farahin@dyna.com.my)

